

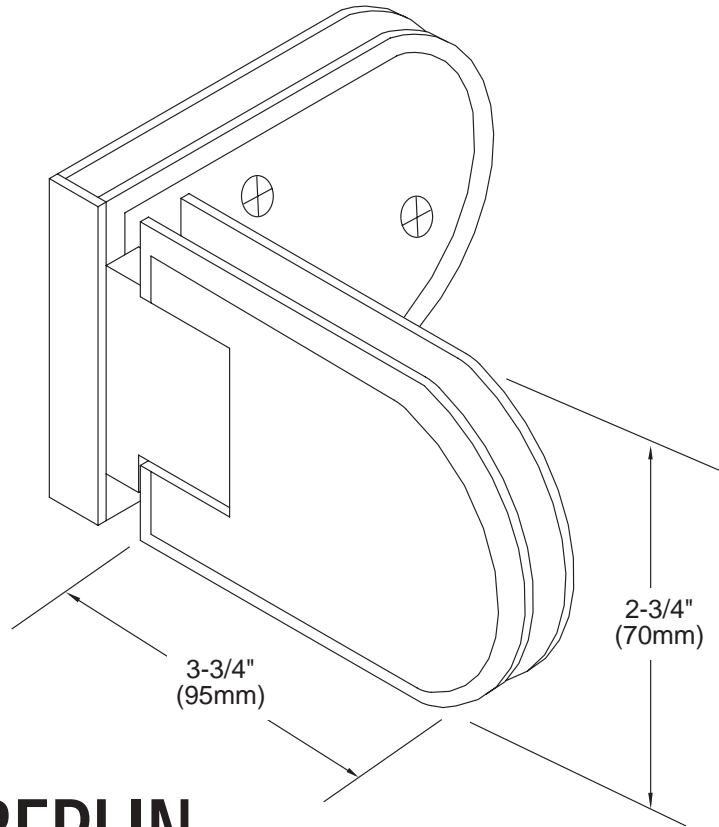

**C.R. LAURENCE CO., INC.**  
PROFESSIONAL QUALITY



# BERLIN

## 90° Glass-to-Glass Hinge

### CAT No. BER090

*Maximum Door Capacities	1/4" (6mm) Glass		5/16" (8mm) Glass	
	Weight	Width	Weight	Width
Using 2 Hinges	60 lbs.(27 kg)	28"(711mm)	60 lbs.(27 kg)	28"(711mm)
Using 3 Hinges	90 lbs.(41 kg)	32"(813mm)	90 lbs.(41 kg)	32"(813mm)

\*NOTE: Do not exceed either maximum weight or width when choosing proper quantity of hinges.

## Important Information:

The door template is a cutout plus a hole.  
 The fixed panel template is holes only.

## Specifications:

**Glass Sizes:** 1/4" (6mm) to 5/16" (8mm) thick tempered safety glass

**Construction:** Solid brass

**Closing Type:** Self-centering when within 15° of closed position

**Cutout Required**

**Includes:** Gaskets, screws and template

## Use of Gaskets:

**For 1/4"(6mm) Glass:** Use one thick gasket on each side

**For 5/16"(8mm) Glass:** Use one thin gasket on each side

## Recommendations:

For public safety, we recommend the use of only tempered safety glass.  
 Do not use power tools when installing these hinges.

## Maintenance Guidelines:

- Never use an abrasive cleaner on the hardware. Many of the components are coated with a clear lacquer that will be irreparably damaged if subjected to harsh, abrasive chemicals. Advise your customer that drying the hardware with a clean, soft towel on a daily basis is the best way to maintain the hardware. If mineral deposits build-up, mix a couple of drops of a mild liquid soap (such as Ivory or a similar product) into a cup of warm water. Using a soft, non-abrasive cloth, clean the hardware. Rinse thoroughly with clean warm water and dry.